

Glycolysis and Cellular Respiration

A quick review on
Cellular Energetics

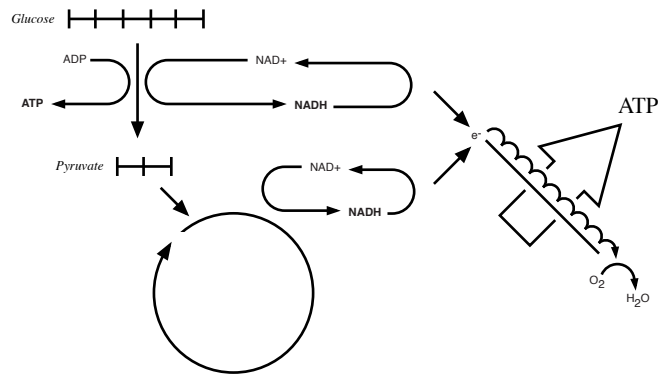

By Noel Ways

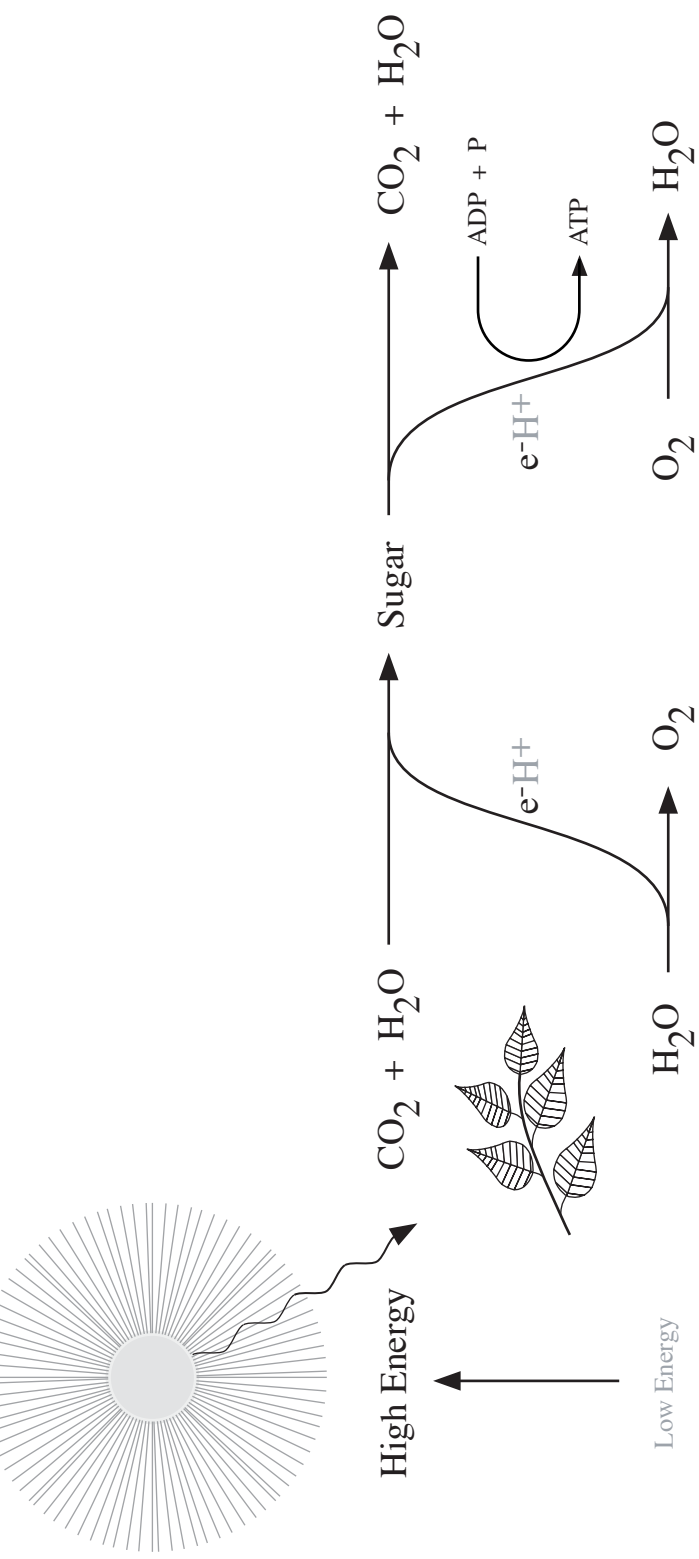

Figure 1

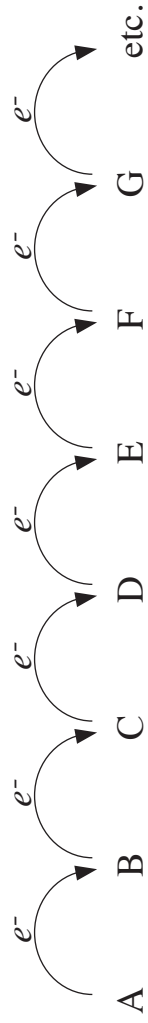

Figure 2

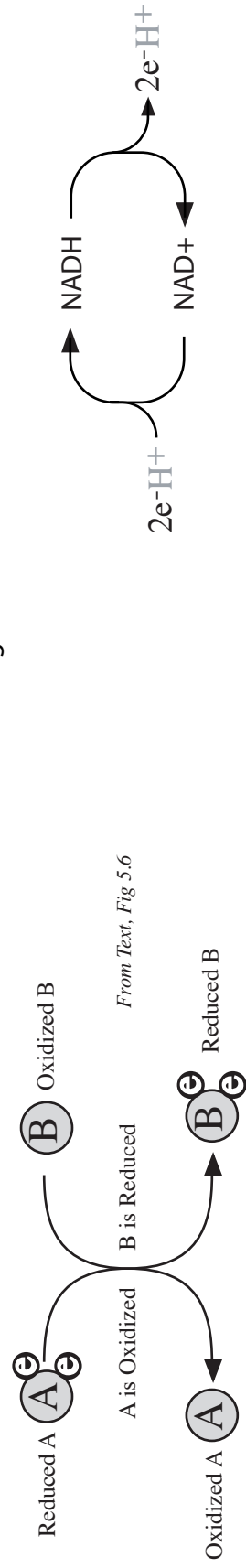
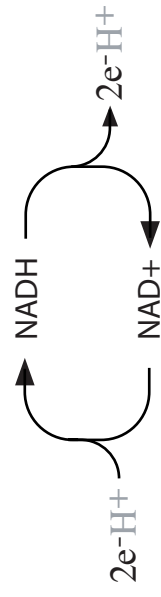
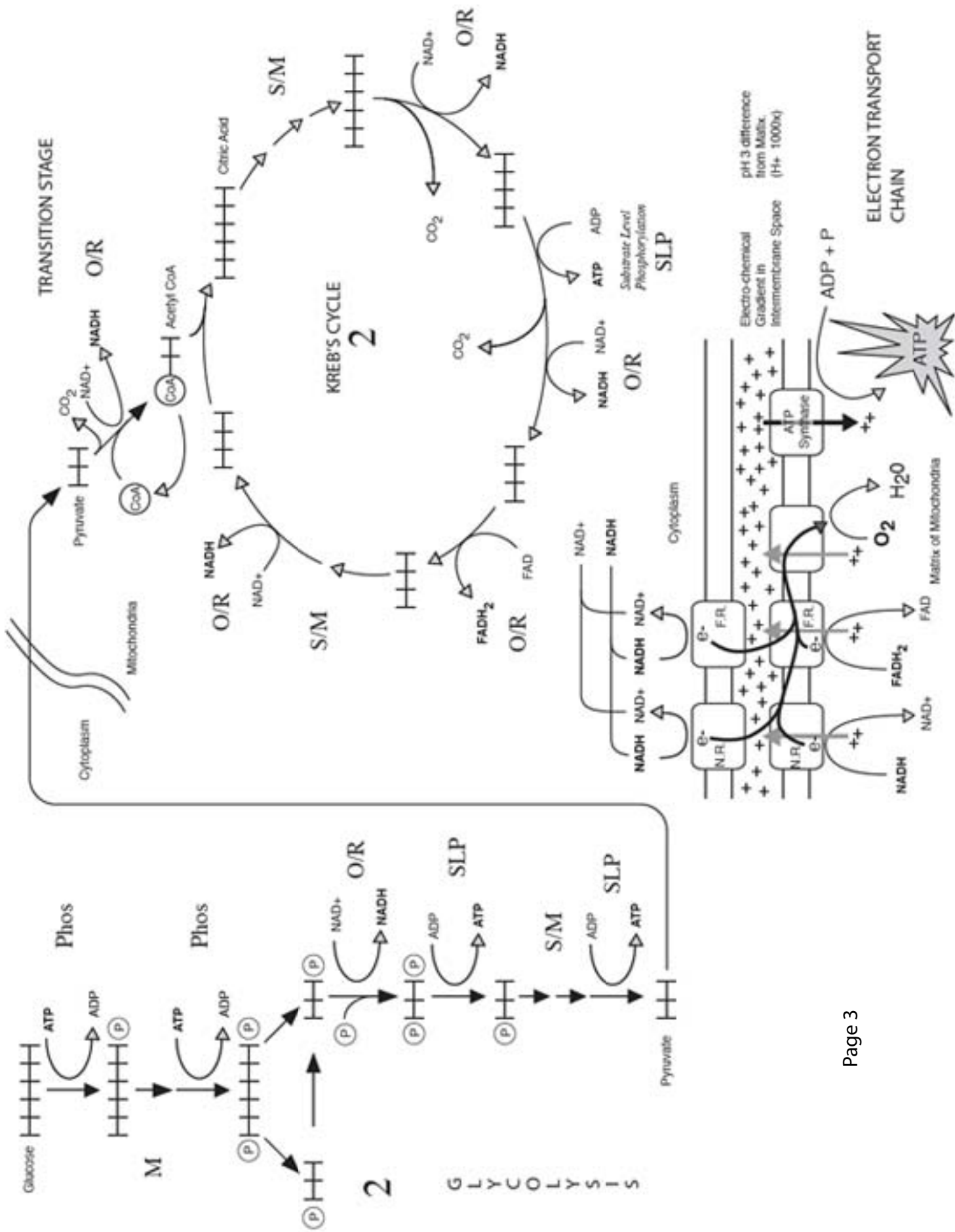

Figure 3

Figure 4





Glycolysis

Glycolysis and Cellular Respiration function to convert glucose (useless for cellular work) into ATP, the only useful energy form for living things. Broadly, this energy transformation process can be broken down into four essential steps.

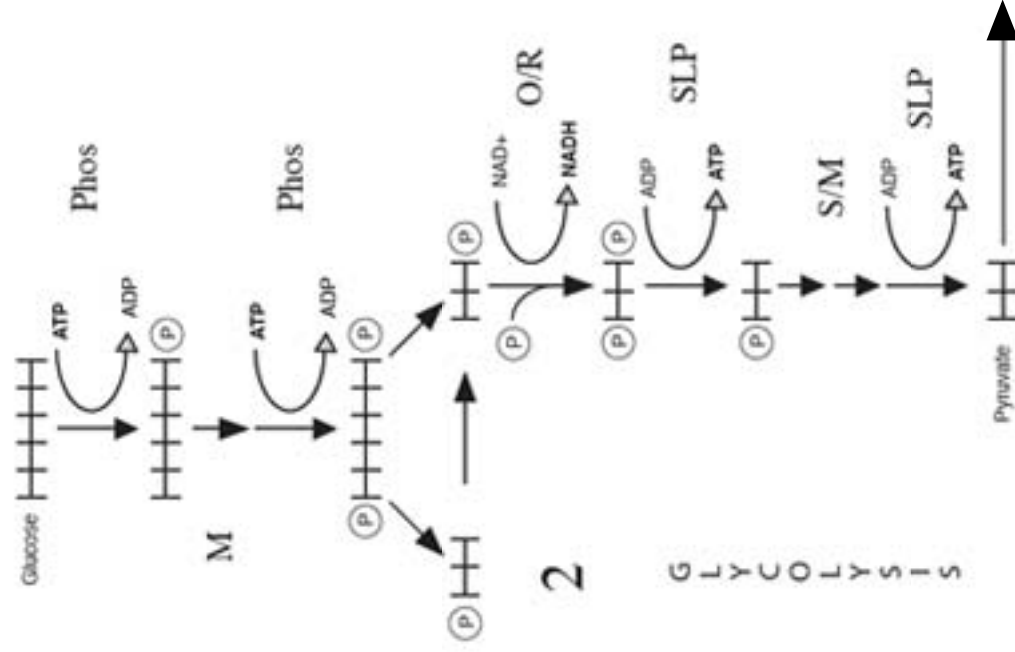

Glycolysis is the first step. This step occurs in the cytoplasm. Here there is a net gain of two ATP. Also, NAD⁺ is reduced to NADH, which is to say it now is “holding” two “high energy electrons”. These electrons will be used to generate more ATP with the “electron transport chain”.

During Glycolysis, the glucose will have been broken down into two molecules of pyruvate.

Transition Stage

Once pyruvate is formed, it enters into the MITOCHONDRIA, where it is “transitioned” into a cyclical set of reactions call the Krebs’ Cycles.

Although there is no ATP production during the transition stage, NAD⁺ is reduced and will again be used to carry “high energy electrons” to the “electron transport chain, where signification ATP production occurs.

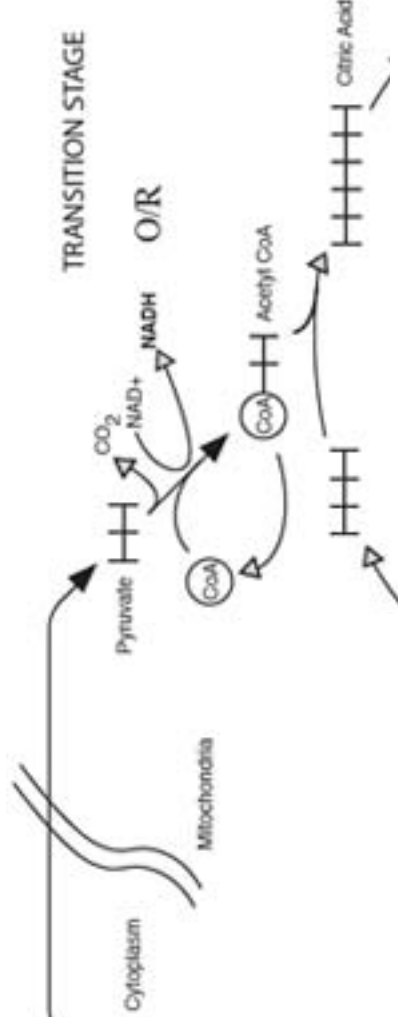

Recall that during this stage, a CO₂ is lost and this results in an acetyl group, which is attached to a Coenzyme A (acetyl CoA). The acetyl group is now incorporated into the Krebs’ Cycle.

Kreb's Cycle

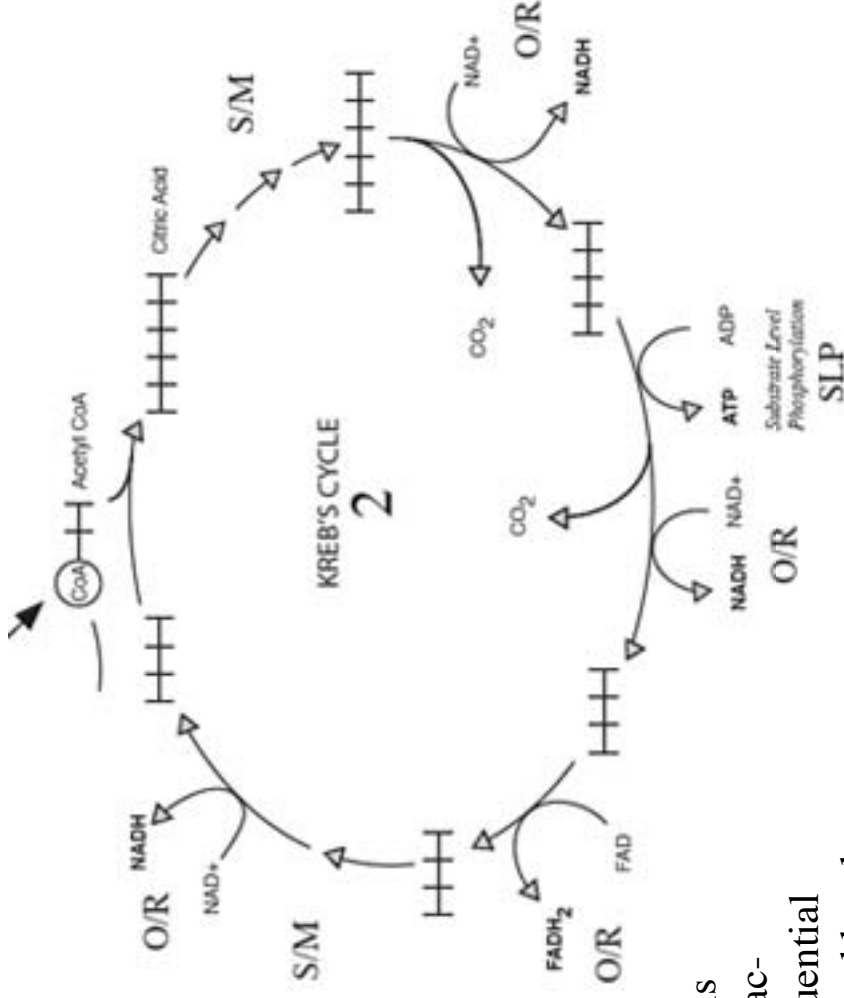

The Krebs's Cycle is a cyclical set of reactions, that in a sequential manner, modifies and breaks down the organic compounds "fed" into it. In this process, substantial "high energy electrons" are "harvested" by way of NAD+ being reduced to NADH. These electrons will again be fed into the "Electron Transport Chain" and for ATP generation purposes.

Recall that during this process, CO₂ is liberated (and will subsequently be exhaled), and that two ATP are generated. In addition, FAD is reduced to FADH₂, and will likewise deliver electrons to the electron transport chain.

Electron Transport Chain

The electron transport chain consists of a series of molecules that receives the “high energy electrons”. These electrons will be allowed to go to lower energy states, and the energy released will be used to generate much ATP. At the end of the line, the now “low energy electrons” will be received by O_2 as waste, and the oxygen will be reduced to water. Oxygen is the final electron acceptor and is the only reason we need oxygen.

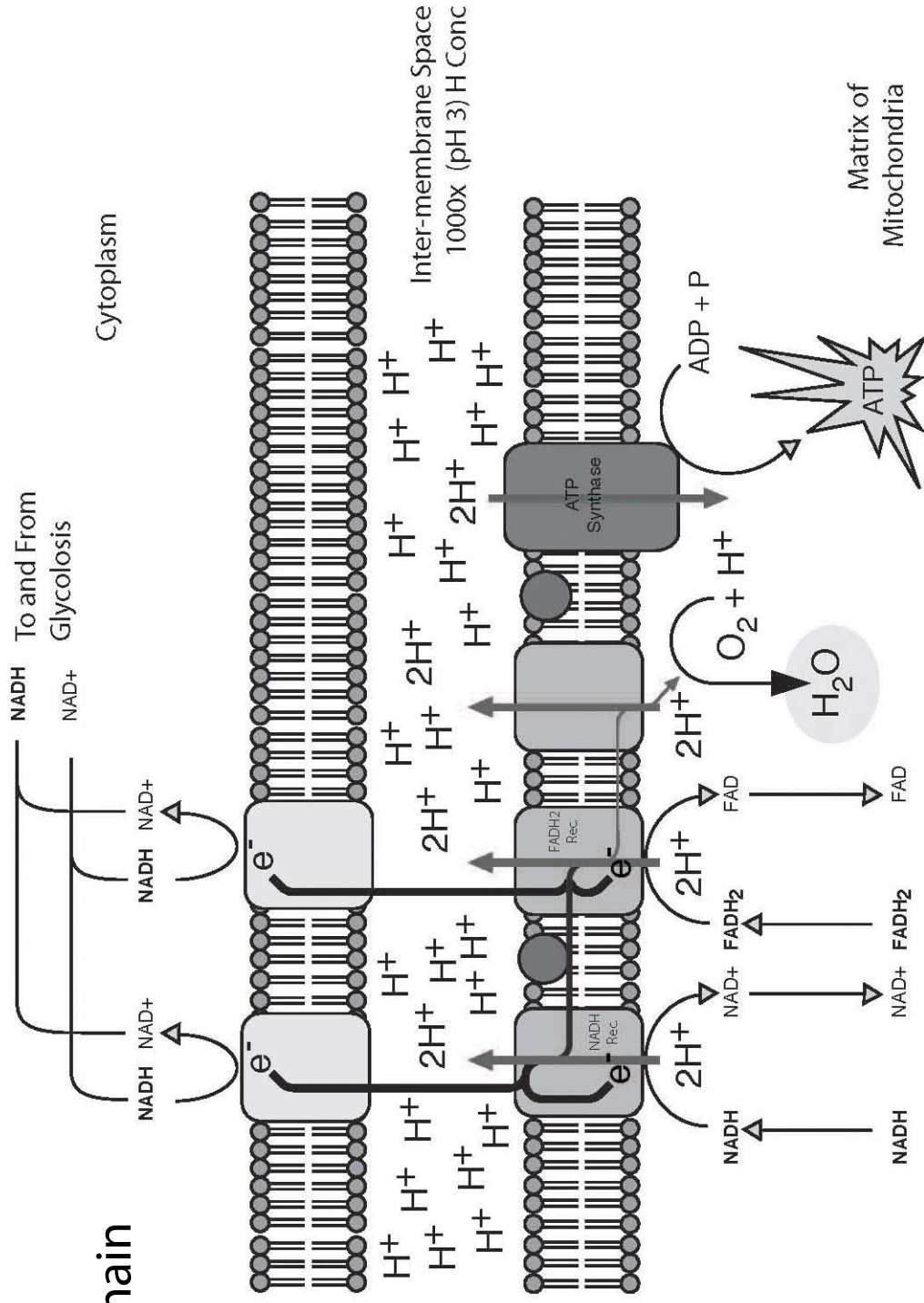

To and From the Krebs's Cycle

Recall that during this process, the energy released by the electrons going to lower energy states will be used to pump H^+ into the inter-membrane space. This will generate an “electrochemical gradient” which will drive ATP production. As the hydrogens return to the mitochondrial matrix through ATP synthase, ATP will be produced.